

MBIHS型衬氟塑料合金离心泵

■ 型号意义

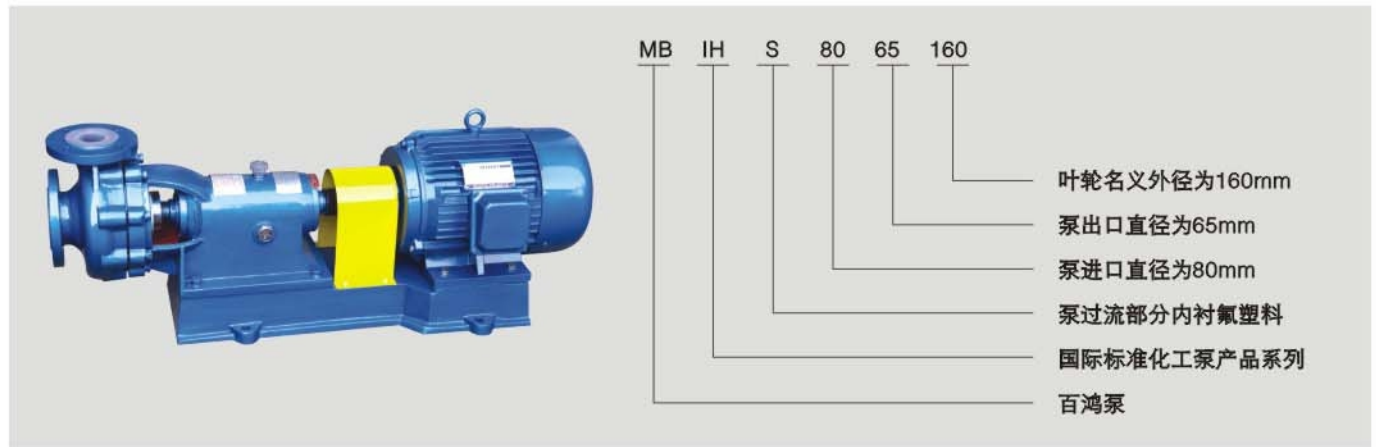

■ 衬氟塑料合金离心泵工作性能表

型号	转速2900r/min					转速1450r/min					允许气蚀余量m
	流量 Qm ³ /h	扬程 Hm	效率 η %	功率KW		流量 Qm ³ /h	扬程 Hm	效率 η %	功率KW		
				轴功率	配用				轴功率	配用	
IHS25-20-145	6.8	22	46	0.9	1.5						2.5
IHS40-32-145	12.5	25	47	1.8	2.2						2.8
IHS50-40-125	7.5	23	47	1		3.75	5.75	45	0.13		3.0
	12.5	20	50	1.36	2.2	6.3	5	48	0.18	0.55	3.0
	15	18	49	1.5		7.5	4.5	46	0.20		3.5
IHS50-32-200	7.5	51	42	2.48		3.75	12.9	42	0.31		3.0
	12.5	50	50	3.4	5.5	6.3	12.5	49	0.44	0.75	3.0
	15	48	45	4.36		7.5	12	46	0.53		3.5
IHS50-40-145	16	28	65	1.88		8	7	50	0.27		3.0
	20	26	71	2	3	10	6.45	56	0.31	0.55	3.0
	25	24	67	2.44		12.5	6	58	0.31		3.5
IHS65-50-160	15	34	45	3.1		7.5	8.55	42	0.42		3.0
	25	32	56	3.9	5.5	12.5	8	52	0.53	1.1	3.5
	30	30	58	4.23		15	7.5	54	0.57		4.0
IHS65-40-200	20	58	58	5.45		15	9	44	0.9		3.0
	25	52	65	5.45	7.5	12.5	12.5	47	0.91	1.5	3.5
	28	48	62	5.90		14	13	49	1		4.3
IHS80-65-160	30	36	65	4.58		15	9	50	0.74		3.0
	50	32	73	5.97	7.5	25	7.75	62	0.85	1.5	3.5
	62	25	69	6.12		30	6.5	61	0.80		4.3
IHS80-50-200	30	55	52	8.64		15	13.5	50	0.74		4.3
	50	50	61	11.16	15	25	12.5	49	1.11	2.2	4
	60	45	60	12.25		30	11.5	51	1.84		4.5
IHS100-80-125	60	23	62	6.06		30	5.75	60	0.79		3.4
	100	20	73	7.46	11	50	5	71	0.96	1.5	3.4
	120	18	70	7.95		60	4.5	72	1.02		4.3
IHS100-80-160	60	36	62	9.49		30	9	58	1.3		3.4
	100	32	71	12.27	15	50	8	69	1.58	2.2	3.4
	120	28	70	13		60	7	68	1.68		4.3
IHS100-80-200	60	56	61	15		30	14	60	1.91		3.4
	100	50	72	18.91	22	50	12	68	2.40	4	3.4
	120	40	69	18.95		60	10	63	2.60		4.3
IHS150-125-315						150	22	71	12.1		3.3
						200	22	81	15.4	22	3.5
						240	18	78	16.9		4.5
IHS200-150-250						250	22	58	25.81		3.4
						300	20	65	25.13	37	3.5
						400	15	50	27.22		4.5

MBIHS型衬氟塑料合金离心泵

■ 型号意义

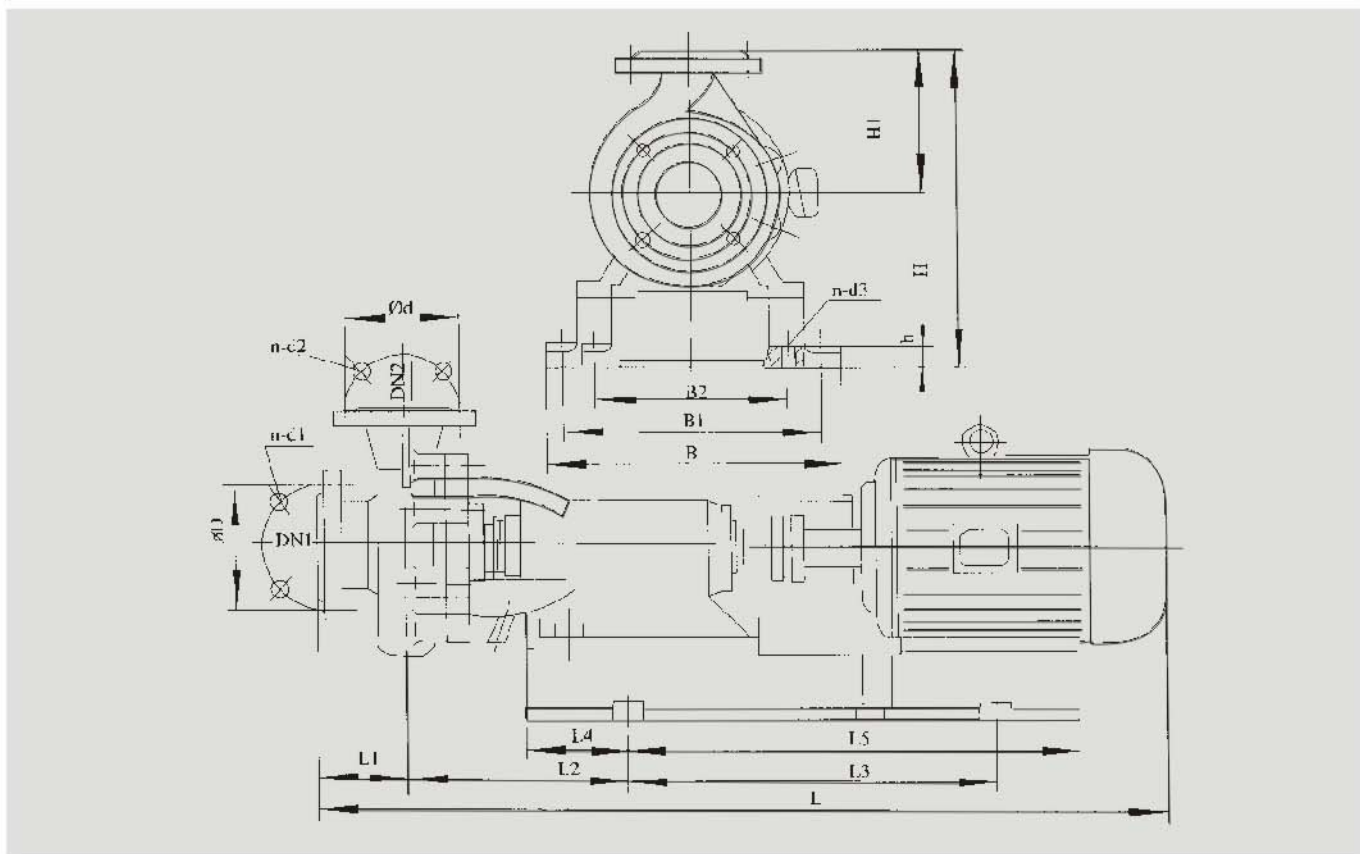

■ MBIHS型泵尺寸表

型号	进口			出口			高度			外形				机座					
	DN1	D	N-φd1	DN2	D	n-φd2	H	H1	H	B	L	L1	L2	L3	L4	L5	B1	B2	n-φd3
IHS25-20-145	25	85	4-14	20	75	4-M12	298	128	20	260	805	80	204	367	93	486	224	/	4-15
IHS40-32-145	40	110	4-18	32	100	4-M16	298	128	20	260	832	80	206	367	93	486	224	/	4-15
IHS50-40-125	50	125	4-18	40	110	4-M16	298	128	20	280	834	80	208	367	93	486	224	/	4-15
IHS50-40-145	50	125	4-18	40	110	4-M16	298	128	20	280	910	80	208	394	93	478	224	/	4-15
IHS50-32-200	50	125	4-18	32	100	4-M16	402	180	27	360	1030	80	266	452	130	556	320	236	4-18
IHS65-50-160	65	145	4-18	50	125	4-M16	390	168	27	360	1046	85	273	452	130	556	320	236	4-18
IHS65-40-200	65	145	4-18	40	110	4-M16	422	200	27	360	1030	90	266	452	130	556	320	236	4-18
IHS80-65-160	80	160	8-18	65	145	4-M16	402	180	27	360	1065	100	277	452	130	556	320	236	4-18
IHS80-50-200	80	160	8-18	50	125	4-M16	474	204	24	428	1384	124	328	600	151	752	380	286	4-18
IHS100-80-125	100	180	8-18	80	160	8-M16	454	184	24	428	1384	124	328	600	151	752	380	286	4-18
IHS100-80-160	100	180	8-18	80	160	4-M16	454	184	24	428	1384	124	328	600	151	752	380	286	4-18
IHS100-80-200	100	180	8-18	80	160	4-M16	514	224	24	453	1390	124	328	627	151	790	405	286	4-18
IHS150-125-315	150	240	8-18	125	210	8-M16	730	350	30	520	1551	165	375	650	200	880	460	360	4-23
IHS200-150-250	200	350	8-22	150	240	8-M16	763	375	30	610	1850	200	388	860	200	1117	550	360	4-23